

WIKIN 1000

UP TO 1000 KG/HR

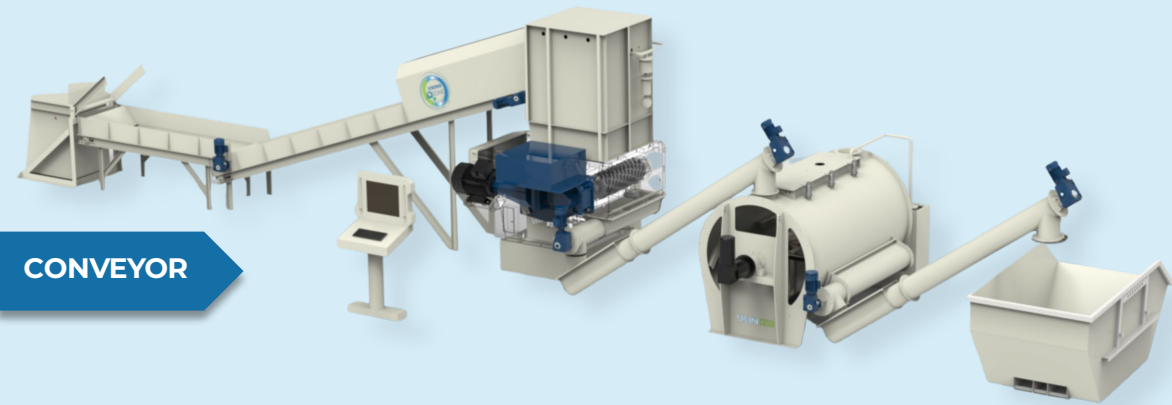

SIDE LIFT BIN



CONVEYOR

More Configurations Available!

TECHNICAL SPECIFICATIONS

- Modular Design, Multiple Configurations
- Conveyor or Bin Lift Dump Options
- Shredding of waste to 25mm, up to 90 % volume reduction.
- High grade ozone produced on board unit
- Separate ozone skid with air compressor
- Efficacy of 6 log 10 reduction
- Up to 1000 kg per hour
- Lifting mechanism cycle up to 33 lifts/hr
- Electricity is the only energy required
- 76 kWh per hour (est)
- ZERO emissions O3 converted back to O2
- Designed and built for 20 + year service
- Waste treated at room temperature, no steam
- Premium stainless-steel construction
- Single shaft shredder by VECOPLAN
- Air compressor / dryer by KAESER
- Oxygen generator by AIRSEP
- OZONE generators by ABSOLUTE
- CE certified for international markets
- Available in 50 Hz or 60 Hz formats
- Online support worldwide

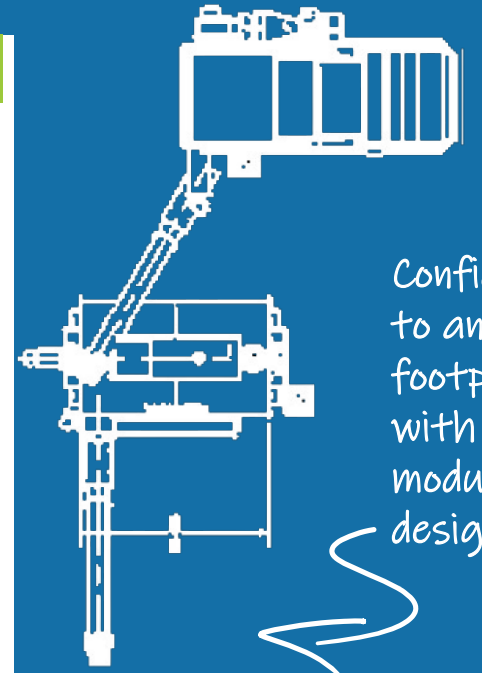

Configure to any footprint with our module design

Separate Ozone Skid with Air Compressor

